

Finger Keeper Industrial

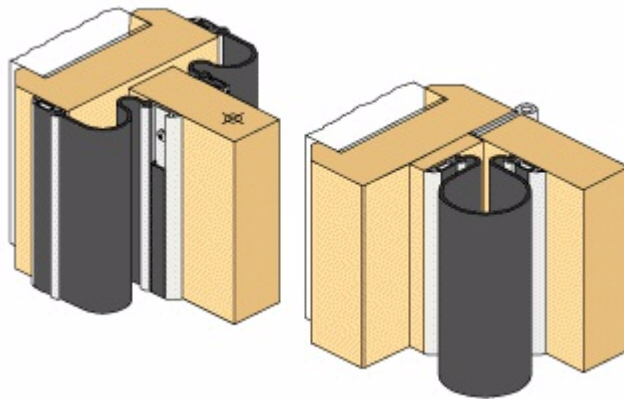

A finger keeper (anti finger trapping guard) to suit the most demanding industrial environments.

Description:

A rubber EPDM safety strip which prevents fingers being jammed on the hinge side of a door and the jamb on the hinged side.

Location:

Butt hinged or centre pivot door.

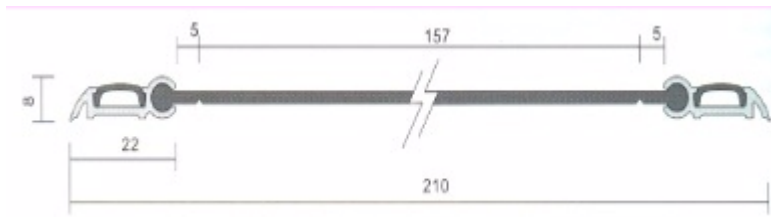

Seal Lengths

2100mm (longer to order).
Can be cut to length required.

Standard Finishes

Anodised Satin Clear
Black EPDM rubber seal.

Fixing Method

Zinc plated, cross recess head S.T. screws of the appropriate size are supplied.
Fixing holes are slotted. Push-in cover strip.

Ordering Information

COLOUR	CODE	SIZE
ALUMINIUM	AFFKIND	2100MM

As part of our policy of ongoing improvements, we reserve the right to modify, alter or change product specifications without giving notice. Product illustrations are representations only. All information contained in this document is provided for guidance only, and as ASTROFLAME FIRESEALS LTD has no control over the installation methods of the products, or of the prevailing site conditions, no warranties expressed or implied are intended to be given as to the actual performance of the products mentioned or referred to, and no liability whatsoever will be accepted for any loss, damage or injury arising from the use of the information given of products mentioned or referred to herein.

The above information to the best of our knowledge is true and accurate and based upon current test data and is supplied for your guidance only. Customers should satisfy themselves to the suitability of the product in its intended use and no guarantee is given or implied since the conditions of actual use are beyond our control. ASTROflame (Fireseals) Ltd, disclaim any liability for loss, damage or other expense arising from the use of information, data or products mentioned or referred to and reserve the right to change any details or specifications without notice.

Astroflame (Fire Seals) Ltd. Intumescent House
Unit 8, The IO Centre, Stephenson Road, Segensworth
FAREHAM, ENGLAND PO15 5RU

tel 0800 023 2482
(01329 844500)

fax 0800 023 2483
(01329 844600)

intl
tel +44 1329 844500

fax +44 1329 844600

email