Trade Name: Fingerkeeper Rearguard:
Rear Fitting Anti-finger trapping device.

COSHH Data

Installation Data

Product Images

Installation Video

Fingerkeeper Rearguard is a child safety, accident prevention product to prevent finger trapping in doors.

Shields the rear hinges of the door.

Fits most door types.

Long anticipated lifespan.

Durable but easily fixed - foolproof design ensures simple DIY fitting.

Low maintenance - wipe clean finish.

Easily removed and refitted to allow for door maintenance.

Sold in 1960mm lengths.

Full fitting kit included.

Avoid litigation and compensation claims.

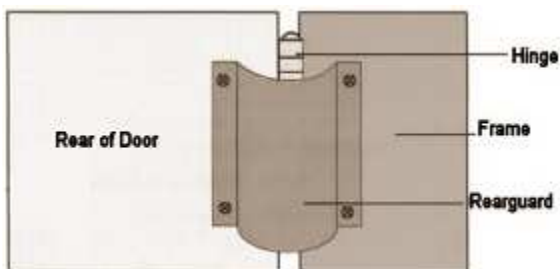

For maximum protection fit in conjunction with Finger Keeper Commercial front hinge covers.

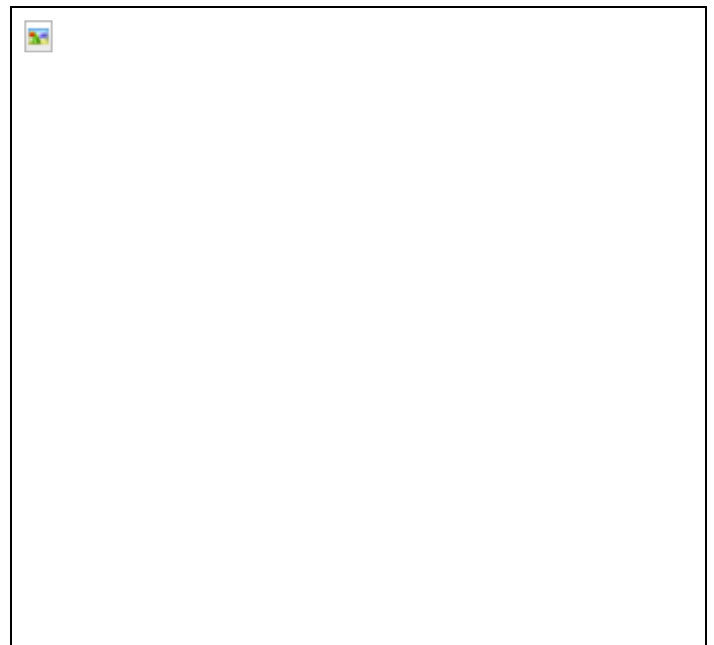

Description

Fingerkeeper Rearguard prevents finger trapping accidents by totally covering the gap that is created on the **rear** hinge side of a

door when it is in the open position.

The Fingerkeeper Rearguard device can be fitted to most types of doors including wood, metal and uPVC.

Used in conjunction with [Fingerkeeper](#), which covers the front hinges, the risk of finger trapping accidents on the hinge edge of the door is eliminated.

The device is considered to be environmentally friendly.

Extremely simple to install and can be removed and refitted as required.

Every year, according to RoSPA, over 30,000 children are injured in the UK as a result of trapping their fingers in doors.

Availability

Fingerkeeper Rearguard is available in 10 different colours to ensure it matches existing décor also available in Teak and Beech finishes (not illustrated).

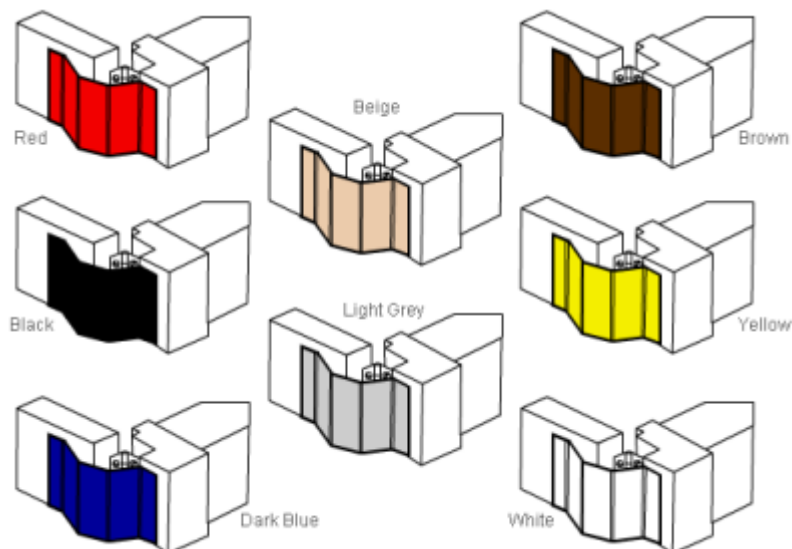

Packing

Sold individually or available to order in any quantity in 1960mm lengths.

Colours: Beech, Beige, Black, Blue, Brown, Cream, Grey, Red, Teak, White and Yellow

To Order & Specify

Please quote - Quantity / Trade Name / Product Code / Colour
Typical wording - 12 / ASTRO FINGERKEEPER REAR/ AFFKBRH / Brown.

Health and Safety

Normal good industrial and personal hygiene practices should be observed.

Installation

Easy to fit. Full instructions supplied or refer to our online installation sheet.

As part of our policy of ongoing improvements, we reserve the right to modify, alter or change product specifications without giving notice. Product illustrations are representations only. All information contained in this document is provided for guidance only, and as ASTROFLAME FIRESEALS LTD has no control over the installation methods of the products, or of the prevailing site conditions, no warranties expressed or implied are intended to be given as to the actual performance of the products mentioned or referred to, and no liability whatsoever will be accepted for any loss, damage or injury arising from the use of the information given of products mentioned or referred to herein.

The above information to the best of our knowledge is true and accurate and based upon current test data and is supplied for your guidance only. Customers should satisfy themselves to the suitability of the product in its intended use and no guarantee is given or implied since the conditions of actual use are beyond our control. ASTROflame (Fireseals) Ltd, disclaim any liability for loss, damage or other expense arising from the use of information, data or products mentioned or referred to and reserve the right to change any details or specifications without notice.



Astroflame (Fire Seals) Ltd. Intumescent House
Unit 8, The IO Centre, Stephenson Road, Segensworth
FAREHAM, ENGLAND PO15 5RU

tel 0800 023 2482
(01329 844500)

fax 0800 023 2483
(01329 844600)

intl
tel +44 1329 844500

fax +44 1329 844600

email sales@astroflame.com

[Homepage.](#)