

# Technical Data Sheet

## Astro DL Cover

Revision 1 - 7th September 2023

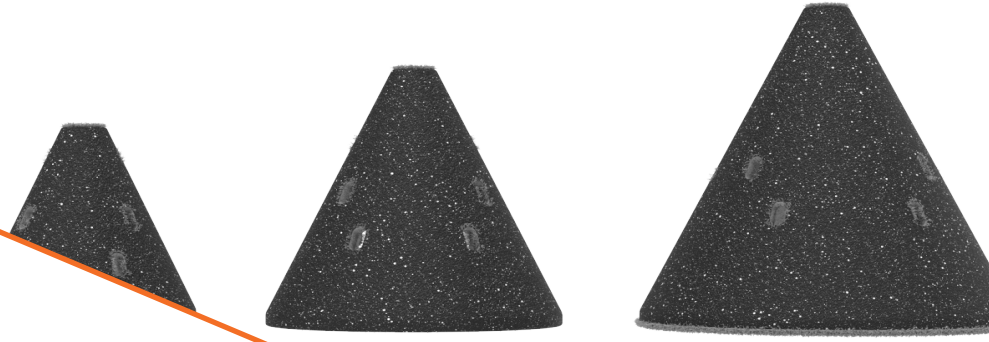



> Technical Data	<b>General Product Description, Product Details, Technical, Installation and maintenance</b>	> Page 1
> Technical Data	<b>Approved Applications - United Kingdom</b>	> Page 2
> Technical Data	<b>Approved Applications - Europe &amp; Italy</b>	> Page 3
> Technical Data	<b>Approved Applications - Australia/New Zealand</b>	> Page 4
> Technical Data	<b>Technical Data</b>	> Page 5
> Technical Data	<b>Sizes &amp; Overall Dimensions</b>	> Page 6
> Technical Data	<b>Fitting Instructions</b>	> Page 7-8
> Technical Data	<b>Storage &amp; Durability, Tools, Intended Use &amp; Maintenance</b>	> Page 9

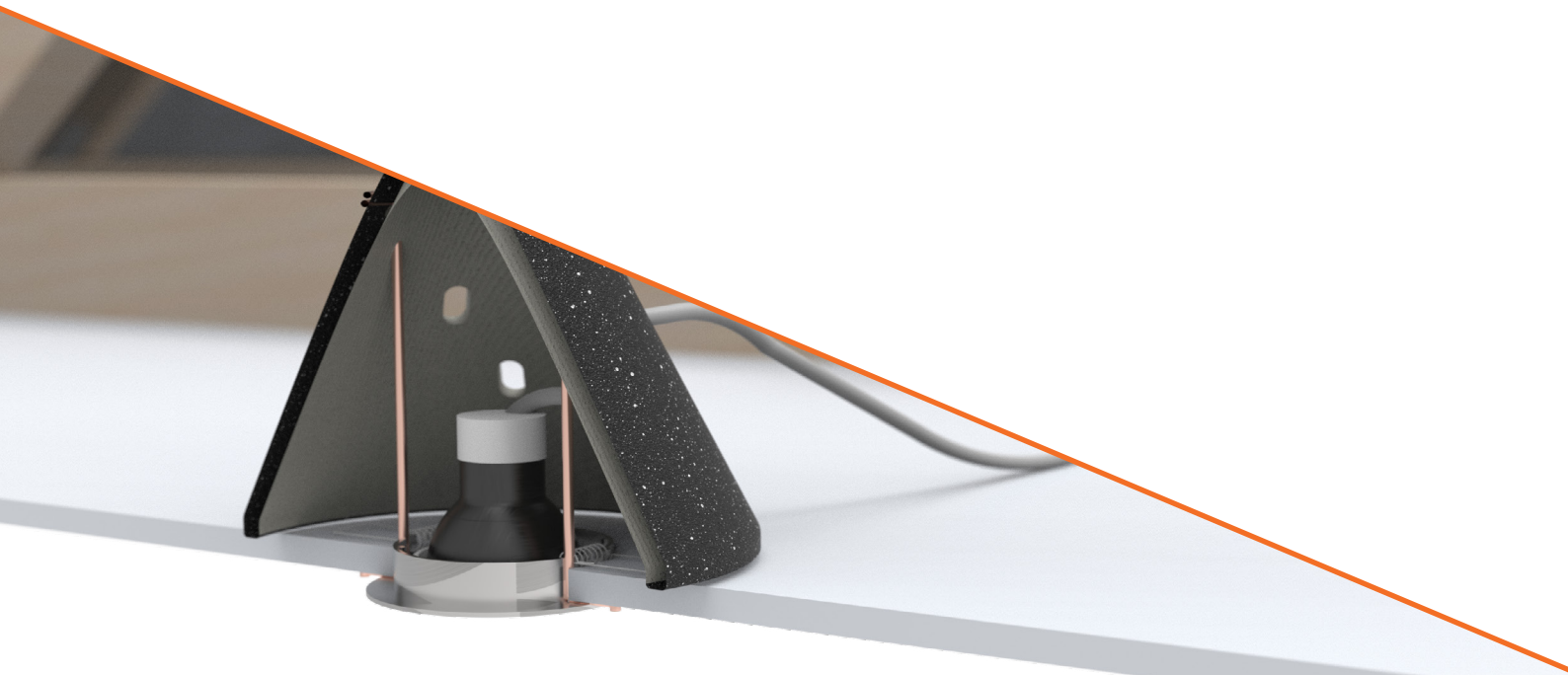

### General Product Description

Astroflame's Downlight Fire Hoods are manufactured from halogen free intumescent material and are designed to reinstate the fire and acoustic performance of ceilings and/or floor constructions when penetrated by downlighters or blank openings if lights are removed for maintenance. The Astro DL Cover is made from an intumescent flexible mineral wool material allowing it to be installed through the hole cut into the ceiling membrane, before springing back into shape to cover the light fitting, whilst allowing enough space between the hood and the light fitting to allow for normal operation of the light fitting.

The Astro DL Cover also includes small ventilation holes, which allows hotter operating downlighters to ventilate, a small pre-cut hole for the light fitting cable to pass through and a steel clip to hold the hood in place. In the event of a fire the Astro DL Cover intumescent material will expand to enclose the ceiling cutout, cable and ventholes, providing effective fire resistance for integrity and insulation for 30, 60 or 120 minutes depending upon the ceiling and floor joist construction, even if the downlight is removed and replaced.

### Product Details

#### Technical

- A fire rated product, reinstating ceiling fire protection up to 120 minutes
- Tested for minimal acoustic noise transfer, ideal for multi-home buildings
- Ventilated design – developed to reduce heat build-up within the Firehood enclosure using a ventilated system
- Suitable for halogen and LED's - available in 3 sizes: 150 x 150 mm, 200 x 200 mm, 250 x 250 mm

### Installation and maintenance

- Flexible and lightweight - designed to be easily and quickly installed from below ceilings with no special tools required
- Compatible with new and retrofit solutions - does not need to be removed when changing light fittings
- No maintenance required after installation

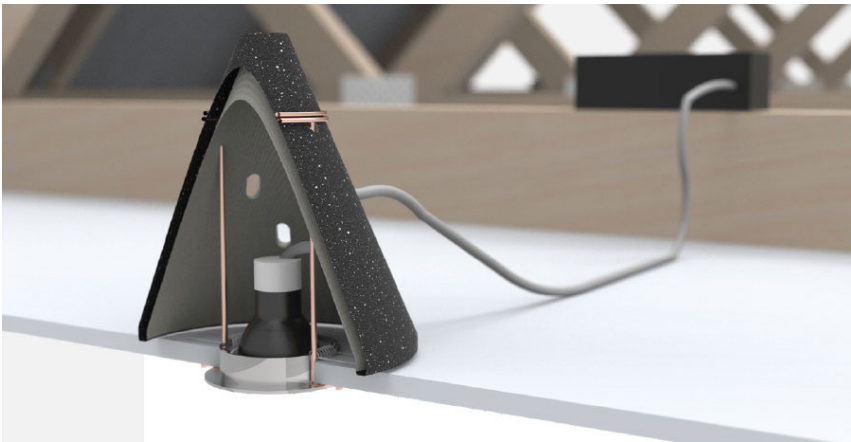

Downlight Hood shields the Downlight insert, this stops flames from below from spreading through the ceiling.



Intumescent material expands when exposed to heat, which stops the flames from spreading.

### Approved Applications - United Kingdom

Astro DL Cover- Downlight Fire Hood 150-250mm							
United Kingdom Fire Performance tested in accordance with BS 476-21/23 1987 and * or ** assessed by Exova Warringtonfire 2018 (Chilt/A02105 rev D)							
Floor Joist Construction Type With Appropriate 60 minutes (REI) Fire Rating	Ceiling Construction Type With Appropriate 60 minutes (REI) Fire Rating	Product Selector			Product Fire Resistance Rating		Tested System and Assessment Reports
		Cut Out Size Range Diameter (Ø in mm )			Integrity	Insulation	
		50 -75	76 - 100	101 - 140			
		Product Dimensions (Outside Width x Height, in mm)					
		150 x 150	200 x 200	250 x 250			
Timber (solid) Floor Joist	Plasterboard	Yes	Yes	Yes	60	60	*BRE TE 94667
Steel I Beam	Suspended Ceiling Grid	Yes	Yes	Yes	60	60	*Chiltern IF99029 + *Warres 66142
Steel I Beam	Suspended Ceiling Grid	Yes	Yes	Yes	60	60	*BRE FG8962/ 208217
Timber (solid) Floor Joist	Plasterboard	Yes	Yes	Yes	60	60	**Warringtonfire A02105 rev D
Composite Steel Web with Timber Chord Joist	Plasterboard	Yes	Yes	Yes	60	60	**Warringtonfire A02105 rev D
Timber (solid) Floor Joist	Suspended Ceiling Grid	Yes	Yes	Yes	60	60	**Warringtonfire A02105 rev D
Composite Steel Web with Timber Chord Joist	Suspended Ceiling Grid	Yes	Yes	Yes	60	60	**Warringtonfire A02105 rev D

### Approved Applications - Europe & Italy

European & United Kingdom Fire Performance tested in accordance with BS EN 1365-2:-2014								
Floor Joist Construction Type With Appropriate 30 or 60 minutes (REI) Fire Rating	Ceiling Construction Type With Appropriate 30 or 60 minutes (REI) Fire Rating	Product Selector			Product Fire Resistance Rating			Tested System Reports
		Cut Out Size Range Diameter (∅ in mm )			Integrity (E)	Insulation (I)	Classification (EI)	
		50 -75	76 - 100	101 - 140				
		Product Dimensions (Outside Width x Height, in mm)						
		150 x 150	200 x 200	250 x 250				
Timber (solid) Floor Joist	Plasterboard	Yes	Yes	Yes	60	60	60	BRE TE 94667
Composite Steel Web with Timber Chord Joist	Plasterboard	Yes	No	No	30	30	30	Warringtonfire WF394530
Composite Timber, OSB Web with Softwood Flanges, Floor Joist	Plasterboard	Yes	Yes	Yes	30	30	30	Warringtonfire WF422978

Italy Fire Performance tested in accordance with UNI EN 13501-2:2009 and UNI EN 1363-1:2012								
Floor Joist Construction Type With Appropriate 120 minutes (REI) Fire Rating	Ceiling Construction Type With Appropriate 120 minutes (REI) Fire Rating	Product Selector			Product Fire Resistance Rating			Tested System Reports
		Cut Out Size Range Diameter (∅ in mm )			Integrity (E)	Insulation (I)	Classification (EI)	
		50 -75	76 - 100	101 - 140				
		Product Dimensions (Outside Width x Height, in mm)						
		250 x 250						
Plastered Reinforced-Concrete/Hollow Clay Tile Floor	Suspended Ceiling Grid	Yes			120	120	120	Istituto Giordano 311120/5599FR

### Approved Applications - Australia/New Zealand

Australia and New Zealand Fire Performance in accordance with AS 1530.4 1997 and assessed by Branz 2017 (FAR 2032 issue 2)								
Floor Joist Construction Type With Appropriate 60 minutes (FRL) Fire Rating	Ceiling Construction Type With Appropriate 60 minutes (FRL) Fire Rating	Product Selector			Product Fire Resistance Rating			Tested System Reports
		Cut Out Size Range Diameter (∅ in mm )			Integrity (R)	Insulation (L)	Classification (RL)	
		50 -75	76 - 100	101 - 140				
		Product Dimensions (Outside Width x Height, in mm)						
		150 x 150	200 x 200	250 x 250				
Solid Timber Floor Joist	Plasterboard	Yes	Yes	Yes	60	60	60	BRE FG8962/208217 and BRE/LPC TE 94667
Steel I Beam	Plasterboard	Yes	Yes	Yes	60	60	60	
Concrete Beam and Floor	Plasterboard	Yes	Yes	Yes	60	60	60	

The fire reports referenced above are undertaken by independent and accredited test houses, the periods of fire resistance indicated within the charts are as detailed within the referenced reports\* and are dependant upon the particular methods of construction being undertaken to reflect those as tested or as approved within the as tested standard. \* Periods of fire resistance are lowered to the nearest National requirements, for example 55 minutes is lowered to 30 minutes or 75 minutes is lowered to 60 minutes. Technical data or certification is provided by Astroflame for reference and is no guarantee that the whole building or construction project will achieve building control approval. This relies upon all building elements, and not just approved Astroflame products.

## Technical Data

Material Property	Astro DL Cover-150	Astro DL Cover-200	Astro DL Cover-250
<b>Physical Properties</b>			
Colour	Black	Black	Black
Material	FF109	FF109	FF109
Thickness - All Tolerances to +2mm/-1mm	8 mm	8 mm	8 mm
Outside Diameter	150 mm	200 mm	250 mm
Height	150 mm	200 mm	250 mm
Weight	0.13 kg	0.14 kg	0.18 kg
Transportation, storage and installation conditions	Product should be kept in dry ambient conditions		
Application temperature	Working life is based on the product being installed in ambient conditions at room temperature (23 °C)		
Cuttability	Product must not be modified as doing so will invalidate the fire protection performance		
Compress ability	Product should not be squashed or compressed other than as per the installation instructions		
<b>Construction Type for Application</b>	Construction types must be suitably tested to achieve the fire performance required		
Maximum aperture	50 -75 mm	76 - 100 mm	101 - 140 mm
LED lamp Wattage, in relation to heat output	Max. 35 Watts	Max. 35 Watts	Max. 35 Watts
Halogen Lamp Wattage, in relation to heat output	Max. 50 Watts	Max. 50 Watts	Max. 50 Watts
<b>Product Performance</b>			
Smoke/Halogen Content	Low Smoke / Zero Halogen	Low Smoke / Zero Halogen	Low Smoke / Zero Halogen
Acoustic measurement as per BS EN ISO 140 part 3 & 6 and calculated to BS EN ISO 717 part 1 & 2	Rw = 65db (when fitted within floor constructions of 86kg/m <sup>2</sup> ) Rw = 42db (when fitted within floor constructions of 34kg/m <sup>2</sup> )		
Density	200 kg/m <sup>3</sup>	200 kg/m <sup>3</sup>	200 kg/m <sup>3</sup>
Free Expansion (Ratio : 1) (@ 450 °C, 15 mins)	5:1	5:1	5:1
Activation Temperature	180°C	180°C	180°C
Thermal conductivity (λ) ISO 8301:1991 and BS EN 12667: 2001	0.0343	0.0343	0.0343

Astro DL Cover Astroflame product must be installed into a construction that matches the corresponding test report. DFH Tenmat product performance requires safe and proper handling and correct installation. For construction projects, all products which the customer is intending to use on a particular project must be approved in writing by the customer's building designer, system designer, design control professional or authorities having jurisdiction, to ensure compliance with the latest regulations. Tenmat can provide the relevant fire test evidence on request.

Sizes

Refer back to Technical Data

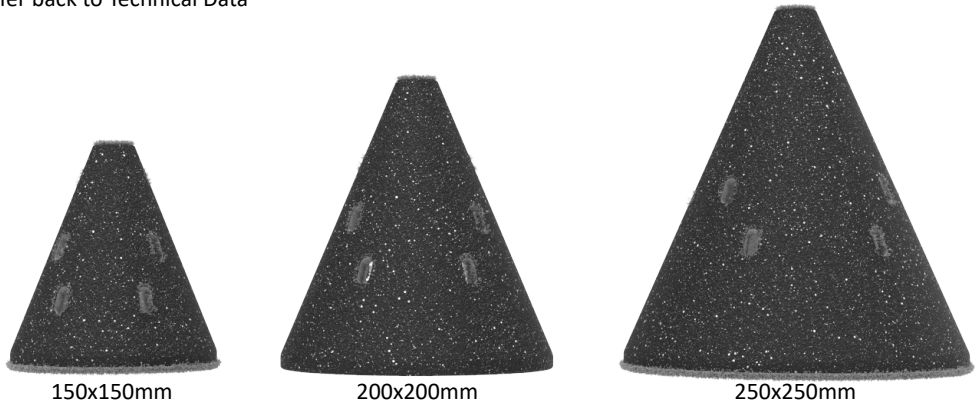

Overall Dimensions

150x150mm

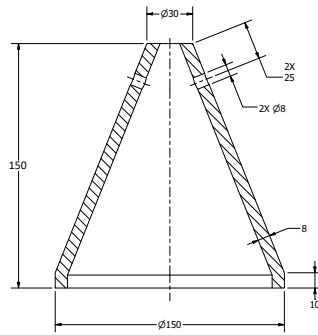

200x200mm

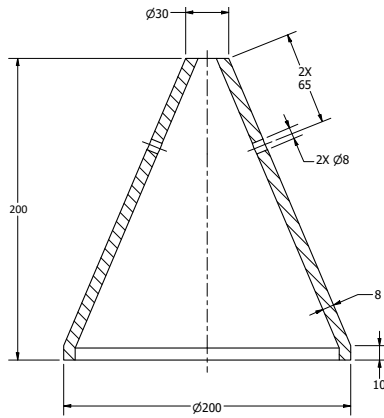

250x250mm

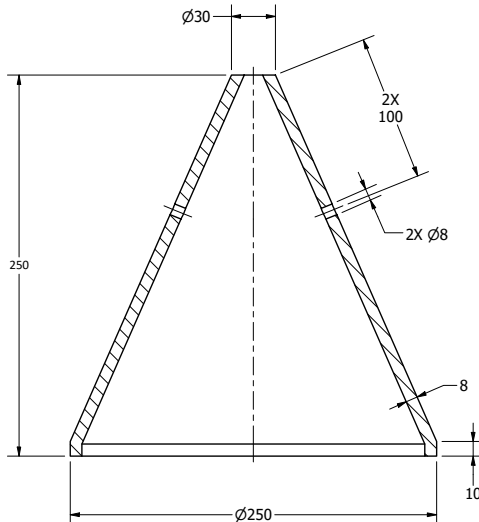



**Fitting Instructions**

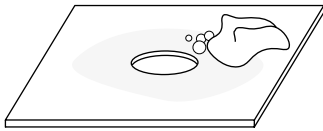

**Step 1**

Using a damp cloth, clean the surface of the ceiling / tile (within the ceiling void / rear side of the tile) to remove any dust or debris within the void.

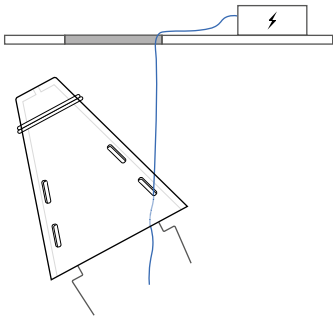

**Step 2**

Ensure that power cable to the downlighter is passed through one of the lowest vent holes (ensuring that the transformer is placed within ceiling void, and not within firehood).

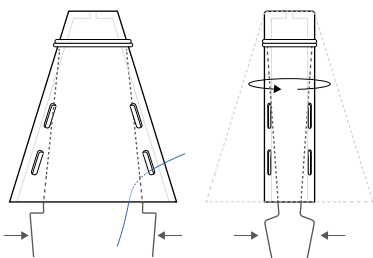

**Step 3**

Grasp legs firmly and roll hood into a tight cylinder. Ensure downlight cable is through one of the lower slots before installation. Ensure transformer is within ceiling void.

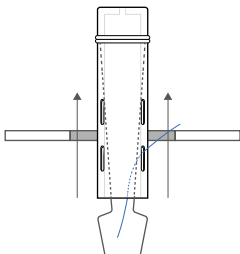

**Step 4**

Keeping a tight grip on the legs, feed the hood through the cut out made for the downlighter.

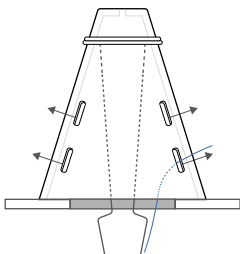

**Step 5**

Ensure hood has sprung back into its original cone shape, this may require you to insert your hand into the hood to push it back into it's original cone shape.

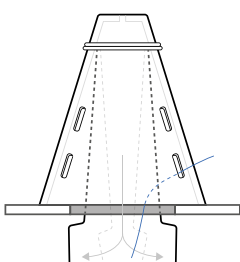

**Step 6**

Grasp legs and pull down until L section, of the legs, clears the underside of the ceiling surface / tile.

**Fitting Instructions (part 2)**

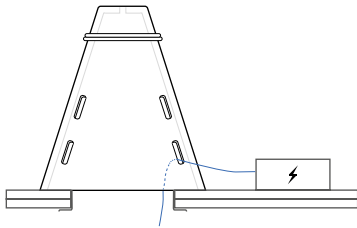

**Step 6 (for thicker ceiling / tile)**

Where the ceiling surface / tile thickness is greater than 15mm ie is double layered then pull firmly down on the legs until L section of legs clears the underside of the ceiling surface / tile.

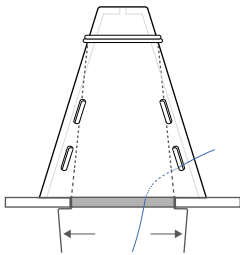

**Step 7**

Move legs out until vertical part of L section is flush with the outside of the cut out, release the legs so they grip the underside of the ceiling surface / tile.

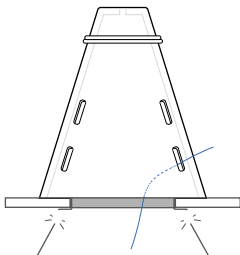

**Step 8**

Remove, by cutting, the excess of both legs (where it protrudes lower than ceiling surface / tile) with wire cutters / pliers.

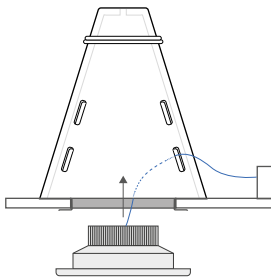

**Step 9**

Once hood is in place, downlighter can be fitted as normal, with the transformer outside the cover.

The product illustrations are the property of Astroflame and have been created for indicative purposes only. Unless indicated below, the photography and illustrations used in this data sheet are the property of Astroflame. We reserve all rights to the usage of these images.

If you require permission to use these images, you must apply for a Usage Agreement. To apply, write to: [sales@astroflame.com](mailto:sales@astroflame.com).

**Storage & Durability**

Storage	:	Dry, ambient
Transportation storage temperature	:	-20°C to +70°C
Working Life	:	48 years
Smoke/Halogen Content	:	Low Smoke / Zero Halogen

---

**Tools**

**PPE AND TOOLS REQUIRED FOR INSTALLATION**

- Hand and eye protection, to protect from ceiling dust and wire cutting
  - Damp cloth to clean surface of ceiling within ceiling void
  - Wire cutters to cut steel wire legs (retaining clip)
  - Step Ladders for access to ceiling
- 

**Intended Use**

Internally used within ceiling voids fitted over recessed downlighters to restate fire resistance performance.

---

**Maintenance**

No active maintenance required, where alterations are made around the product such as changing installed light fitting or transformer the Downlight Fire Hood, Astro DL Cover, should be checked visually to ensure that the product is still installed as per the approved tested systems.



### Installation

We have technical representatives who provide assistance in the selection and specification of the products on this site and should be consulted for exact installation and product suitability. Ensure an early engagement with ourselves, designers, main contractor and specialist installers before any installation. Other trades and/or manufacturers may need to be consulted. For in-depth information, specification and technical advice please call our Head Office on tel [01329 844 500](tel:01329844500) or email [sales@astroflame.com](mailto:sales@astroflame.com)

### Maintenance

All interested parties, designer, specifier, main contractor and specialist installers should provide access to allow the fire stopping seals to be regularly inspected and maintained, as well as records kept of such maintenance at minimum periods of 12 months, as required by the Regulatory Reform Order, and repaired if necessary. Reference should be made to the relevant Code of Practice for the Installation and Inspection of Fire Stopping.

### Competency

It is vital that those entrusted to design or install a fire stopping product have the necessary levels of competence to undertake the task professionally and thoroughly. The level of competency required will be commensurate with the expected complexity of the building. All designers must eliminate, reduce or control foreseeable risks that may arise during installation, construction or maintenance when preparing or modifying designs. Clients should ensure that the principal designer and principal contractor carry out their duties under CDM regulations. The ASFP foundation course in passive fire protection provides essential knowledge as part of demonstrating competency and understanding in this key fire protection specialism.

### Additional Notes

For further information on installation requirements please refer to the lighting fitting or suspended ceiling manufacturer data to ensure the compatibility of this product, if in doubt please contact the technical team on tel [01329 844 500](tel:01329844500) or email [sales@astroflame.com](mailto:sales@astroflame.com)

As part of our policy of ongoing improvements, we reserve the right to modify, alter or change product specifications without giving notice. Product illustrations are representations only. All information contained in this document is provided for guidance only, and as ASTROFLAME (FIRE SEALS) LTD has no control over the specific application or installation methods of the products, or of the prevailing site conditions, no warranties expressed or implied are intended to be given as to the actual performance of the products mentioned or referred to, and no liability whatsoever will be accepted for any loss, damage or injury arising from the use of the information given of products mentioned or referred to herein.

The above information to the best of our knowledge is true and accurate and based upon current test data and is supplied for your guidance only. Customers should satisfy themselves to the suitability of the product based on the products limitation of applications and that the product is fit for purpose for their intended use and no guarantee is given or implied since the conditions of actual use are beyond our control. ASTROFLAME (FIRE SEALS) LTD, disclaim any liability for loss, damage or other expense arising from the use of information, data or products mentioned or referred to and reserve the right to change any details or specifications without notice. If you are in any doubt as to the suitability of this product for your intended application please contact our technical team on 01329 844500 or email [sales@astroflame.com](mailto:sales@astroflame.com) and we will contact you.